



ALLWYN ENTERPRISE

UNIT-1:31, SHAYONA ESTATE, NEAR VADILAL ICE FACTORY,
TAVDIPURA, DUDHESHWAR ROAD, SHAHIBAUG,
AHMEDABAD-380 004, GUJARAT, INDIA.

E-mail: info@valvemanufacturer.in

DRN
MASUM

DATE
27/08/2011

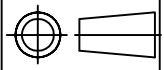

WAFER TYPE BUTTER FLY VALVE.

DRG. NO : AE/BFV/200-300

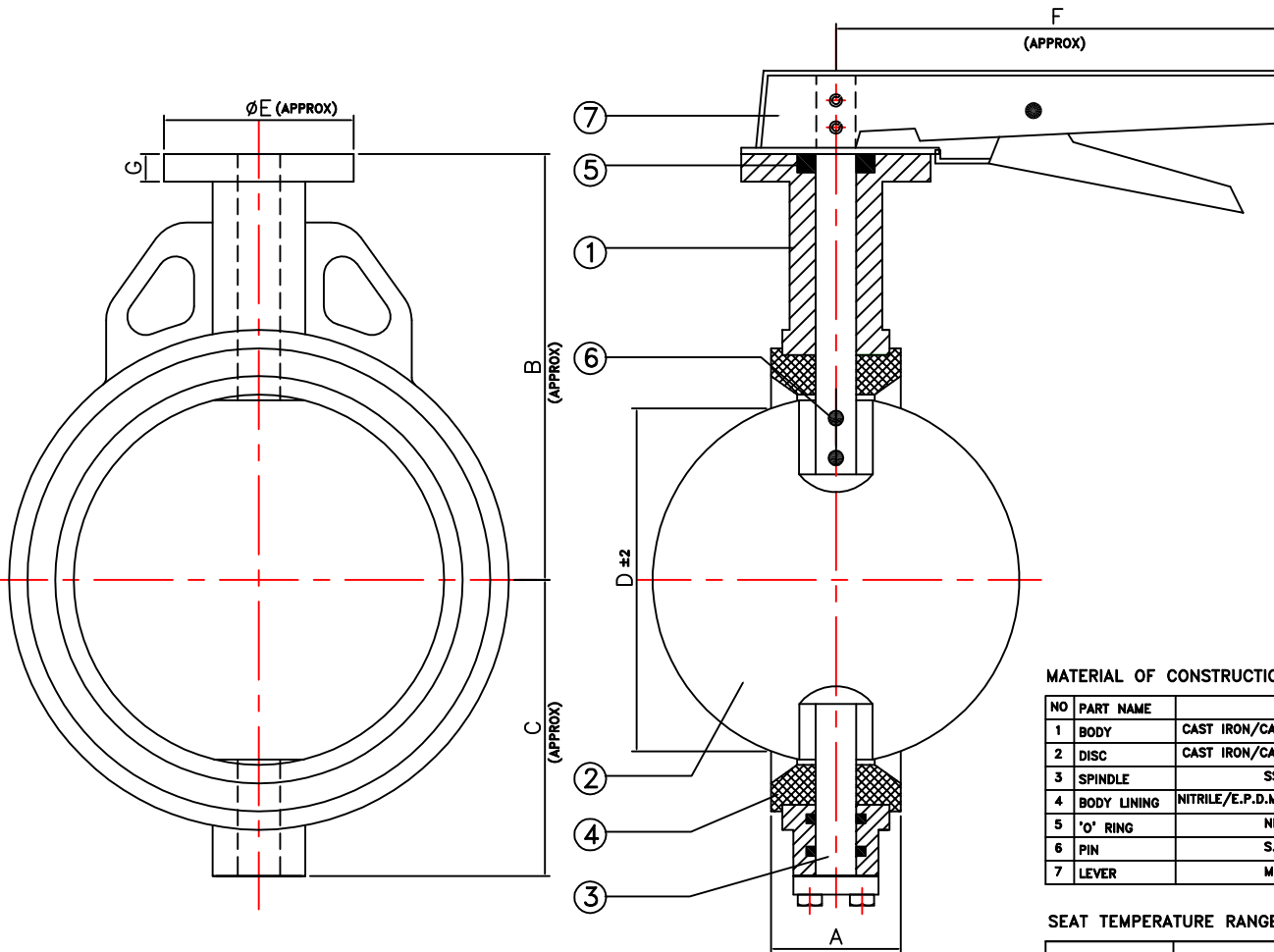

MATERIAL OF CONSTRUCTION

NO	PART NAME	MATERIAL
1	BODY	CAST IRON/CAST STEEL/S.S.304-316
2	DISC	CAST IRON/CAST STEEL/S.S.304-316
3	SPINDLE	SS 410/304/316
4	BODY LINING	NITRILE/E.P.D.M./SILICON/VITON/HYPALON
5	'O' RING	NITRILE / E.P.D.M.
6	PIN	S.S.304/316
7	LEVER	M.S. FABRICATED

SEAT TEMPERATURE RANGE

SEAT TYPE	TEMPERATURE RANGE	
	Min.	Max.
NITRILE	-13°F(-25°C)	212°F(100°C)
EPDM	-13°F(-25°C)	250°F(120°C)
SILICON	-58°F(-50°C)	356°F(180°C)
VITON	-23°F(-5°C)	392°F(200°C)
HYPALON	-4°F(-20°C)	250°F(120°C)

TESTING

PRESSURE RATING	HYDROSTATIC SHELL TEST		HYDROSTATIC SEAT TEST	
	Kg/CM2	PSI	Kg/CM2	PSI
PN16	22	310	16	225
PN10	15	210	10	140

NOTE : ALL DIMENSION ARE IN MM.

SIZE		A	B	C	D	E	F	G	FLANGE MOUNTING (I.S.O 5211)
MM	INCH								
200	8"	60	230	156	194	75	325	15	F10
250	10"	68	266	196	243	75	385	18	F10
300	12"	78	300	230	292	75	385	18	F10

CONFORMITY TO CODES & STANDARDS

- 1) GENERAL DESIGN & MANUFACTURE :- BS 5155 / API 609 / EN 593 / IS 13095
- 2) VALVE FACE TO FACE DIMENSION :- BS 5155 / ISO 5752 / API 609
- 3) TOP FLANGE DRILLING :- ISO 5211
- 4) VALVE INSPECTION & TESTING :- BS 6755 Part - I / API 598 / EN 12266-1
- 5) FLANGE STANDARD CONFORMITY :- ANSI 150 / ANSI 125 / BS 10 TAB D & E
IS 6392 NP 0.6 / 1.0 / 1.6

THIS DRAWING IS PROPERTY OF ALLWYN ENTERPRISE.
ALLWYN ENTERPRISE RESERVES RIGHTS OF USE, CHANGE & MODIFY PRODUCT DESIGN OR PRODUCT WITHOUT PRIOR NOTICE.

CHECKED BY :-

APPROVED :-