



ALLWYN ENTERPRISE

UNIT-1:31,SHAYONA ESTATE , NEAR VADILAL ICE FACTORY,
TAVDIPURA,DUDHESHWAR ROAD , SHAHIBAUG,
AHMEDABAD-380 004 , GUJARAT, INDIA.

E-mail: info@valvemanufacturer.in

DRN	DATE	
MASUM	3/09/2011	

FORGED CARBON STEEL GLOBE VALVE 1500#

DRG. NO : AE/F-GLV/15-40

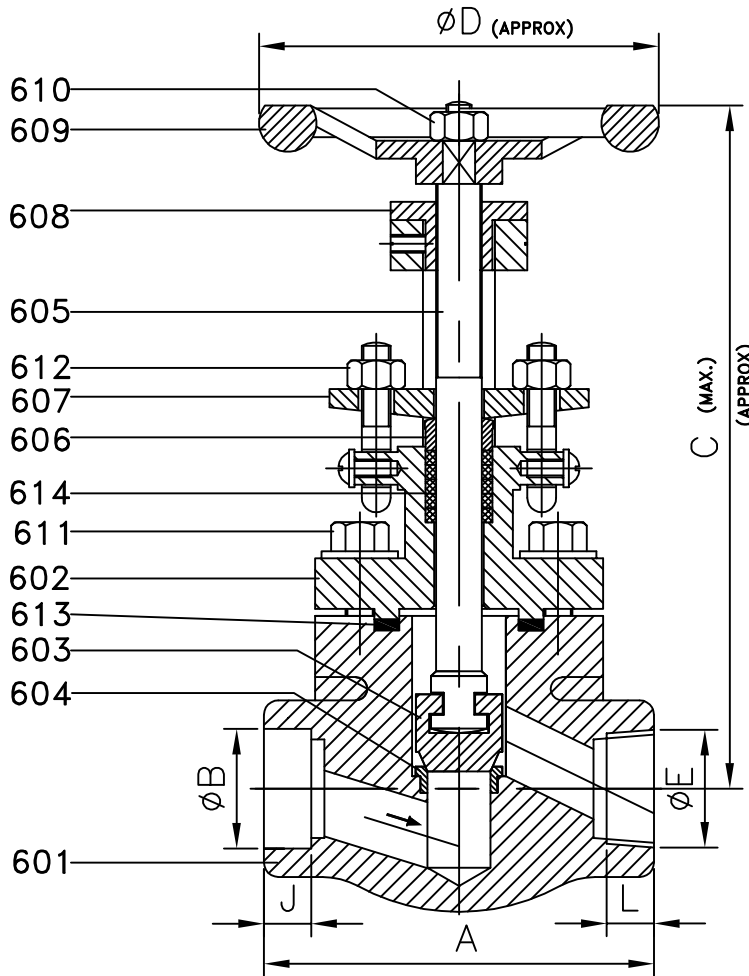

SOCKET WELD ENDS

SCREWED ENDS

DIMENSION TABLE 1500#

SIZE		A	C	ØD	SCREWED ENDS		SOCKET WELD ENDS		J MIN.
MM	INCH				ØE	L	ØB		
						MAX.	MIN.		
15	½"	92	180	90	½"	13.56	22.22	21.72	9.65
20	¾"	105	202	90	¾"	13.87	27.56	27.05	12.7
25	1"	127	260	145	1"	17.35	34.29	33.78	12.7
40	1½"	140	272	145	1½"	18.38	49.15	48.64	12.7

MATERIAL OF CONSTRUCTION

SR.NO.	PARTS NAME	MATERIALS		
601	BODY	A 105	F 304	F 316
602	BONNET	A 105	F 304	F 316
603	DISC	AISI 410	AISI 304	AISI 316
604	SEAT RINGS	AISI 410	AISI 304	AISI 316
605	SPINDLE	AISI 410	AISI 304	AISI 316
606	GLAND BUSH	AISI 410	AISI 304	AISI 316
607	GLAND FLANGE	A 105	F 304	
608	YOKE SLEEVE	ASTM A 439 Gr.D2/AL-BRONZE		
609	HAND WHEEL	CAST STEEL / M.I		
610	HAND WHEEL NUT	Gr.2h		
611	STUD & NUT	B7/2H	B8/8 OR B7/2H	
612	EYE BOLT & NUT	B7/2H	B8/8	
613	GASKET	SPW S.S.304/316 WITH CAF/GRAF OIL		
614	GLAND PACKING	GRAPHITE ASBESTOS INHIB.INCONEL WIRE REIN.		

TESTING

PRESSURE RATING	HYDROSTATIC SHELL TEST	HYDROSTATIC SEAT&BACKSEAT TEST
	Kg/CM2	Kg/CM2
1500#	383	281

NOTE:-ALL DIM. ARE IN MM

CONFORMITY TO CODES & STANDARDS

- 1) GENERAL DESIGN :- BS 5352
- 2) TESTING :- BS 6755 (Part-1)
- 3) TYPE :- BOLTED BONNET, OS & Y. NARROW SEAT TYPE DISC.
- 4) RATING :- CLASS 1500
- 5) FACE TO FACE :- AS SHOWN
- 6) END CONNECTION :- SCREWED ENDS TO BSP/BSPT/NPT
SOCKET WELD ENDS TO ANSI B16.11

THIS DRAWING IS PROPERTY OF ALLWYN ENTERPRISE.
ALLWYN ENTERPRISE RESERVES RIGHTS OF USE, CHANGE & MODIFY PRODUCT DESIGN OR PRODUCT WITHOUT PRIOR NOTICE.

CHECKED BY :-

APPROVED :-